



**National Power Corporation**  
**Access To Sustainable Energy Program - Project Management Office (ASEP-PMO)**

**REQUEST FOR QUOTATION**

July 13, 2023

Sir/Madam:

Please provide us with your best offer for the items as specified in the Terms of Reference (TOR) for **Supply and Delivery of Site Marker of RNS Sites for ASEP-PMO** and submit the same on or before **July 18, 2023** at the **ASEP-PMO Office, 2F, ABDC Building, Sct. Rallos, cor Sct. Tuason St., Diliman, Quezon City** or via e-mail at [aseprns.npc@gmail.com](mailto:aseprns.npc@gmail.com) or at [acfrobles@napocor.gov.ph](mailto:acfrobles@napocor.gov.ph)

The following documents will also be required in case your submitted quotation will be evaluated as most responsive in our requirement:

1. Valid Mayor's Business Permit;
2. Other documents/licenses that may be required.

For further inquiries, please contact Mr. Alfel Caesar F. Robles at mobile no. 09086031847 with e-mail address at [acfrobles@napocor.gov.ph](mailto:acfrobles@napocor.gov.ph).

Thank you and looking forward to your response on this request the soonest.

Respectfully yours,

  
**GODOFREDO B. MAGPOC, JR.**  
Project Director, ASEP-PMO

BIR Road cor. Quezon Avenue, Diliman  
Quezon City 1100, Philippines  
Tel. Nos. (632) 921-3541 to 80  
Fax No. (632) 921-2468  
Website: [www.napocor.gov.ph](http://www.napocor.gov.ph)

AFG-LOG-004.F01  
Rev. No. 0  
Page 1 of 1





NATIONAL POWER CORPORATION

Access To Sustainable Energy Program - Project Management Office (ASEP-PMO)

TERMS OF REFERENCE  
SHOPPING

1. **Scope of Works: For the Supply and Delivery of Site Markers for Rural Network Solar (RNS) Sites of ASEP-PMO**

Item No.	DESCRIPTION	QTY. / UNIT
1	Site marker, stainless steel 304, chemical etch engrave (logo & text), with reflex blue background (see attached detailed design) Dimensions: (2 metal sheets per set per site) 1)1810 mm x 675 mm x 2 mm thickness 2)1895 mm x 360 mm x 2 mm thickness	4 sets
<b>•Notes:</b> <b>•Mode of Award: per LOT basis</b>		

2. **Delivery Period**

Delivery Period shall not be later than TEN (10) CALENDAR DAYS upon receipt of the Purchase Order.

3. **Delivery Point**

Items shall be delivered at ASEP-PMO OFFICE, GreatWork Studio 2F ABDC Building, Sct. Rallos, cor Sct. Tuason St, Diliman, Quezon City

4. **Bid Submission**

The Bidder shall submit their bids through their authorized representative or in the manner of submission as prescribed in the Request For Quotation.

5. **Late Bids**

Any Bid submitted after the deadline for submission and receipt of Bids shall not be accepted by NPC.

6. **Bid Prices**

The bid price as indicated in the Quotation Form shall be fixed during the Bidder's performance of the Contract and not subject to variation or price escalation on any account. A Bid submitted with an adjustable price quotation shall be treated as non-responsive.

7. **Bid Price Validity**

Price Validity shall not be less than One Hundred Twenty (120) calendar days from date of bid submission.

## **8. Eligibility Criteria**

- a. Bids shall be checked using the PASS / FAIL Criteria for Legal, Technical and Financial components.
- b. From the bids that were rated PASSED, the same shall be ranked and corrected for computational errors to identify the Most Responsive Quotation (MRQ).

## **9. Detailed Evaluation and Comparison of Bids**

The MRQ shall be subjected to detailed evaluation against the Scope of Works including arithmetical computations. Documents which are deemed not to comply with the requirements of the tender shall be considered non-complying.

## **10. Post-qualification**

Submitted documents of the MRQ shall be subjected to post qualification evaluation. The bid that PASSED the Post-Qualification shall be declared as the Most Responsive and Evaluated Quotation (MREQ).

## **11. Total Contract Price**

The Total Contract Price shall be inclusive of all taxes and other related expenses / charges.

## **12. Notice to Supplier**

- a. The supplier shall pick-up the Purchase Order (PO) from ASEP-PMO office within two (2) calendar days from receipt of the Notice of Award.
- b. Failure to secure the PO by the supplier within the said period will mean cancellation of the same and imposition of penalties as prescribed by law.

## **13. PO Effectivity**

- a. The PO Shall take effect immediately upon receipt of the PO by the supplier sent through letter or any electronic means and as confirmed by the supplier's representative.

## **14. Terms of Payment**

Terms of Payment shall be thirty (30) calendar days after submission of complete supporting documents.

## **15. Warranty**

Warranty is dependent upon the nature/type of the item which is included in the offer (i.e. Manufacturer's Warranty).

## **16. Reservation Clause**

ASEP-PMO reserves the right to accept or reject any bid, to annul the bidding process, and to reject all bids at any time prior to contract award, without thereby incurring any liability to the affected bidder/s.

**SUPPLIER'S BID QUOTATION  
 (SHOPPING)**

To: ASEP-PMO Project Director :

I have read and examined the Terms of Reference for the **Supply and Delivery Site Markers for RNS Sites of ASEP PMO**. I agree with the conditions of the TOR and offer the following supplies with specific description:

ITEM NO.	DESCRIPTION OF ITEM / S TO BE SUPPLIED (INCLUDE BRAND NAME)	QTY	UNIT PRICE (PhP)	TOTAL PRICE (PhP)
1	Site marker, stainless steel 304, chemical etch engrave (logo & text), with reflex blue background (see attached detailed design) Dimensions: (2 metal sheets per set per site) 1) 1810 mm x 675mm x 2mm thickness 2) 1895mm x 360mm x 2mm thickness	4 sets		
<b>TOTAL BID PRICE</b>				

\_\_\_\_\_  
 Name and Signature of Authorized Representative

Date \_\_\_\_\_

Company Name \_\_\_\_\_

Contact Details \_\_\_\_\_

e-mail address \_\_\_\_\_

*Note: The bidder may use this form or its own company letter head following this format duly signed by the authorized representative when making the offer.*

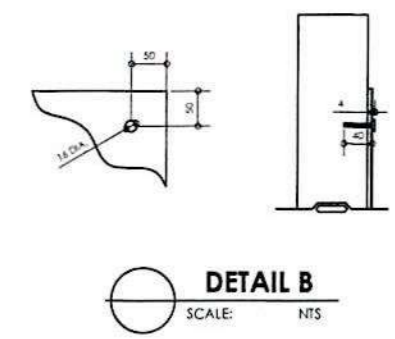
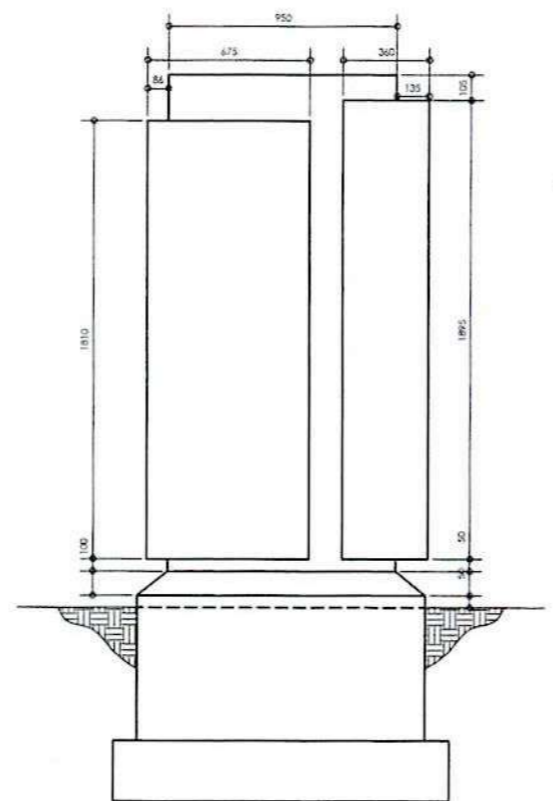
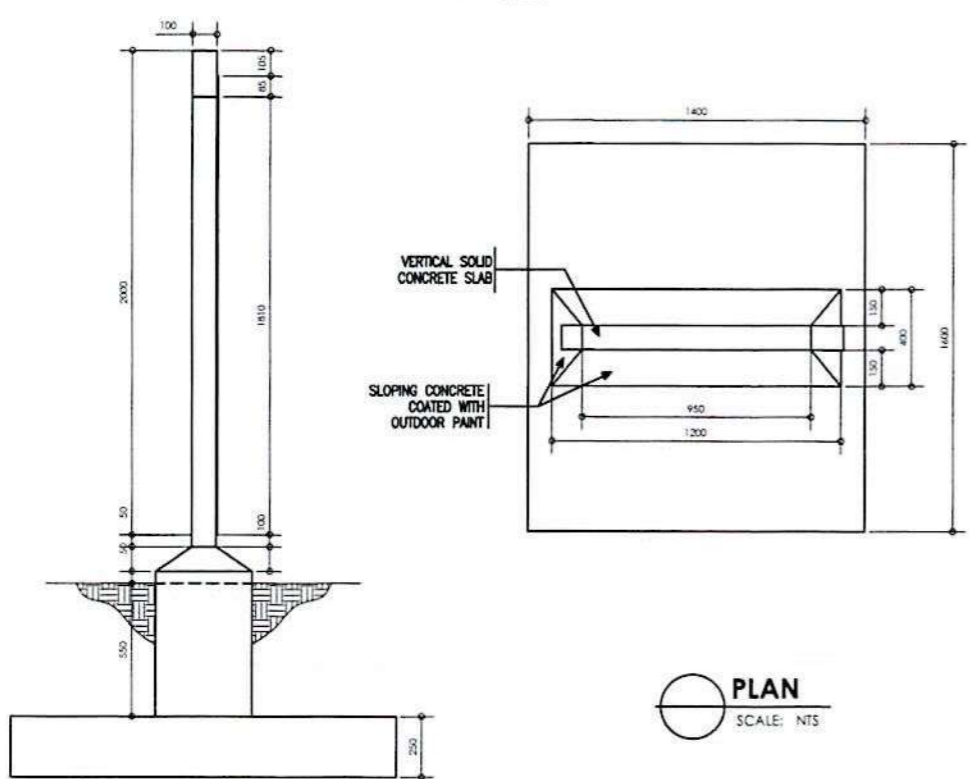
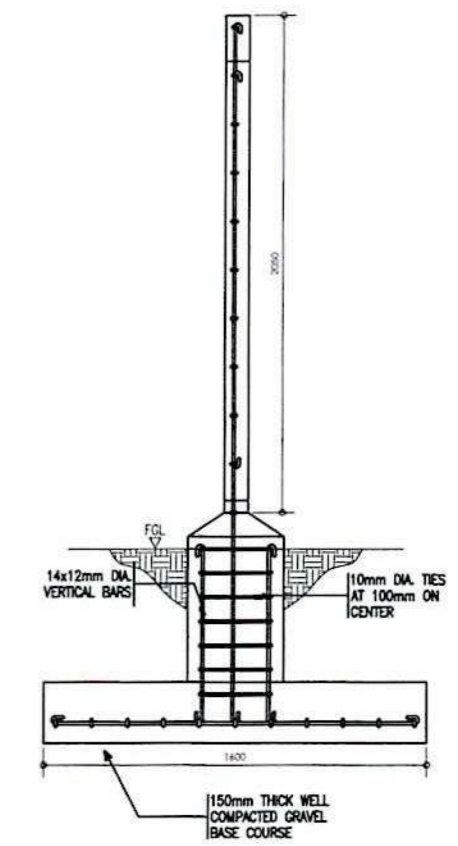
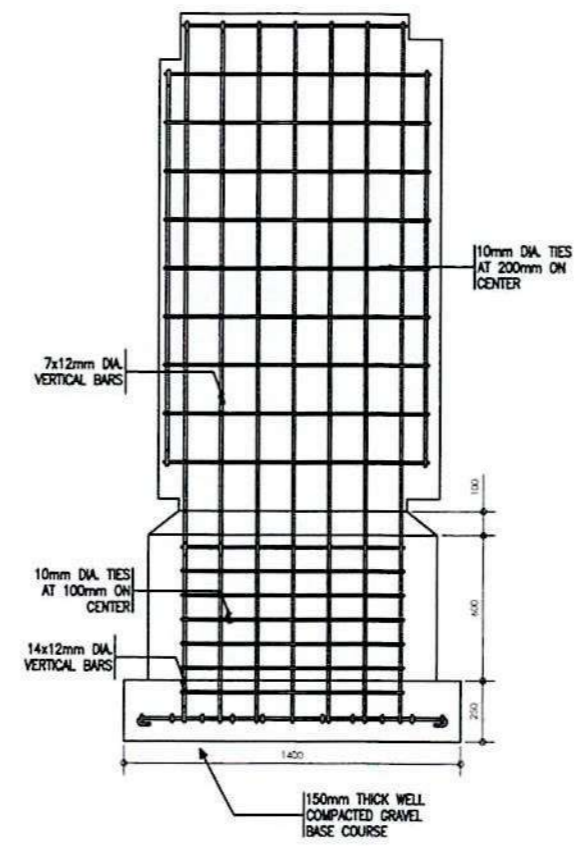
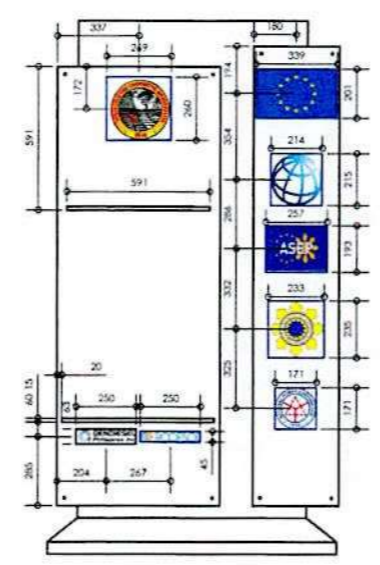
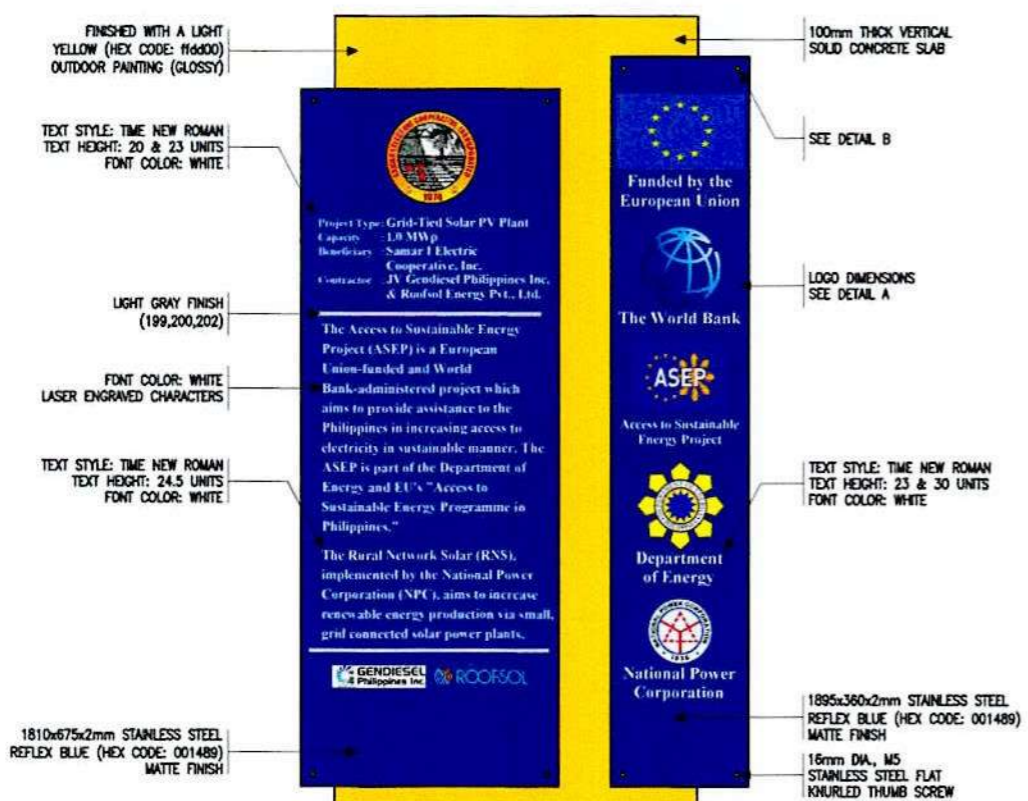

**SITE MARKER FOUNDATION DETAILS**  
SCALE: NTS

OWNER:		<b>NATIONAL POWER CORPORATION</b> AGHAM ROAD, DILIMAN, QUEZON CITY	
PROJECT: DESIGN, SUPPLY AND INSTALLATION OF 7x1.0MWp GRID-TIED SOLAR FARM FOR LUZON, VISAYAS AND MINDANAO ELECTRIC COOPERATIVES (LOT 4 - SAMELCO I)			
LOCATION: BRGY. CARAYMAN, CALBAYOG CITY, SAMAR			
TITLE:		<b>SITE MARKER</b>	
DESIGNED	BY	CHKD	DATE
DRAWN			SUBMITTED: _____
REVIEWED	PRINCIPAL ENGR. / ARCHT.		RECOMMENDED: _____
CIVIL/ARCHT			APPROVED: _____
ELEC.			
MECH.			
DWG. NO.		SPECS. NO.	
SCALE: AS SHOWN		<b>SAMPLE DRAWING</b>	
REV.		DATE	
NATURE OF REVISION		BY	
CHKD.		RECD.	
APPD.		REV. <b>0</b>	

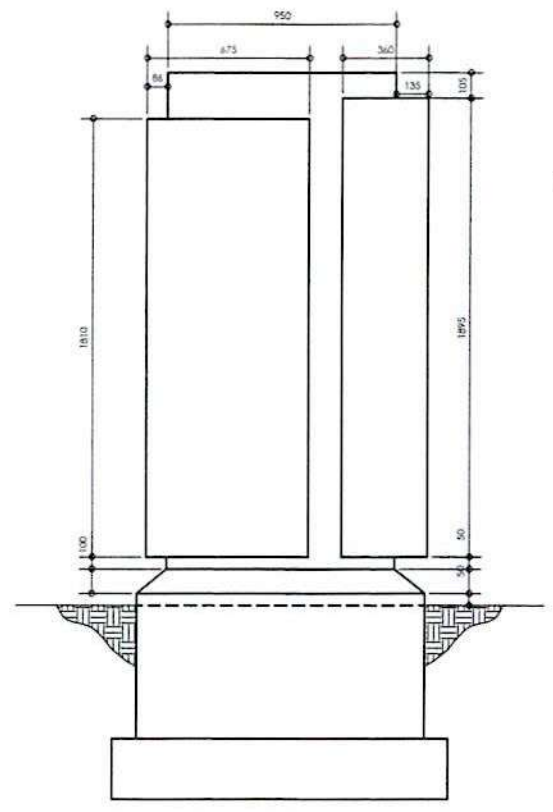
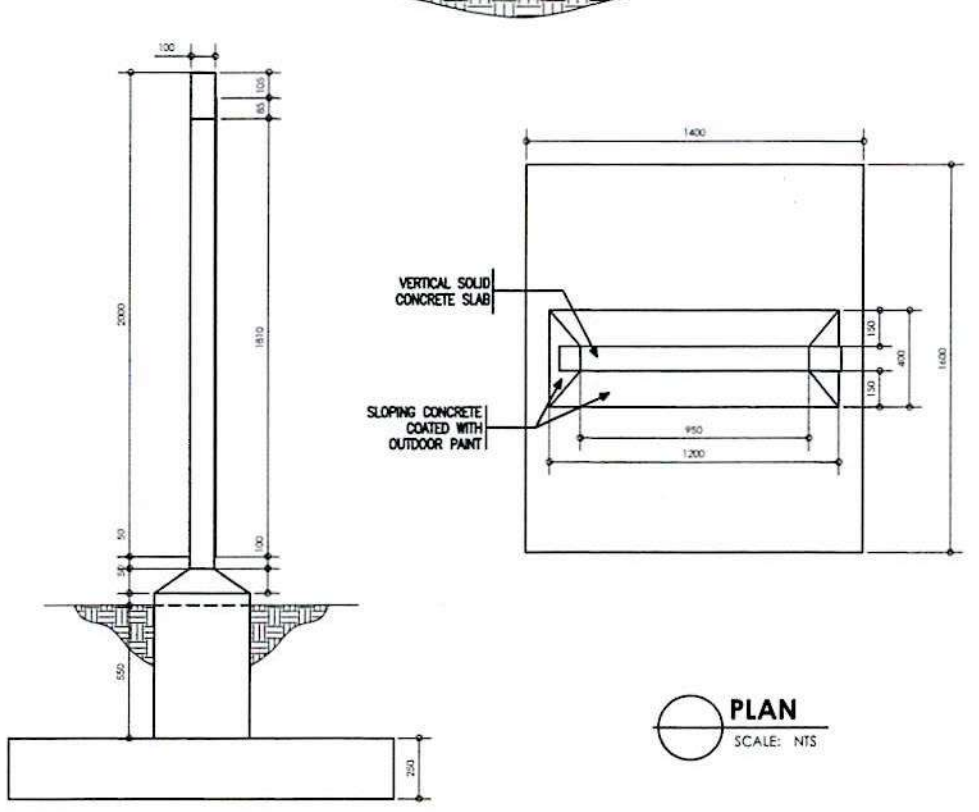
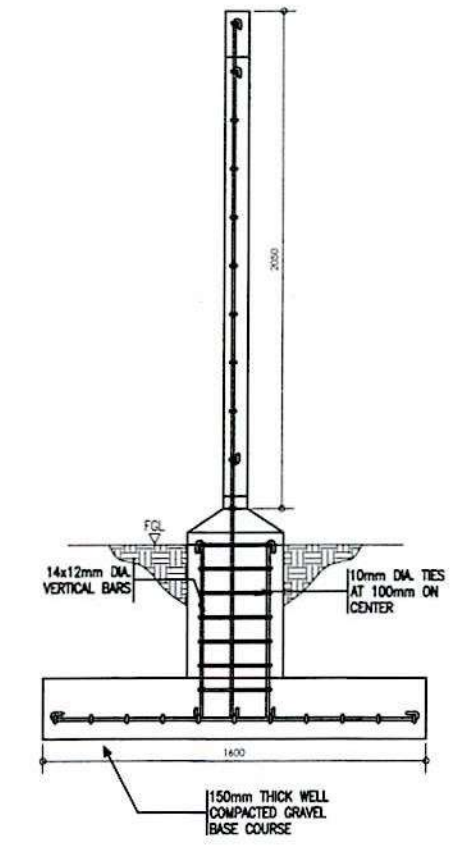
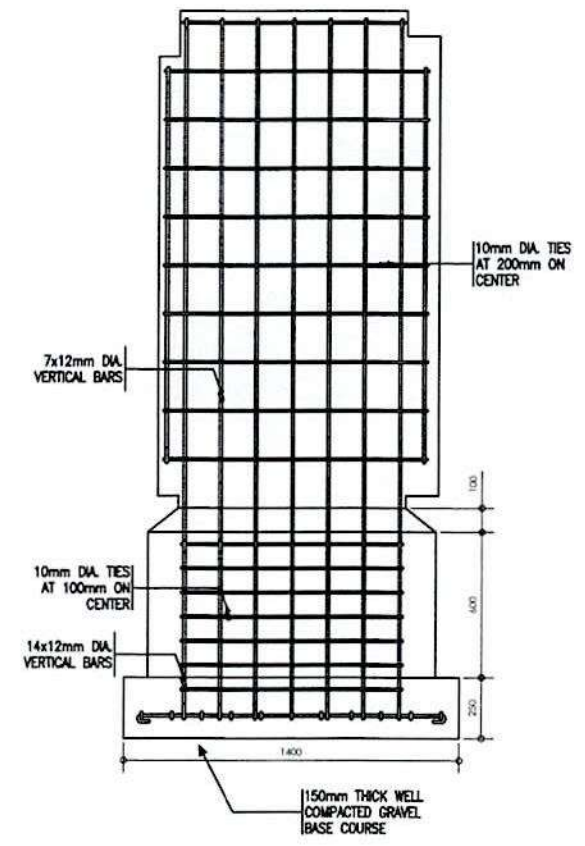
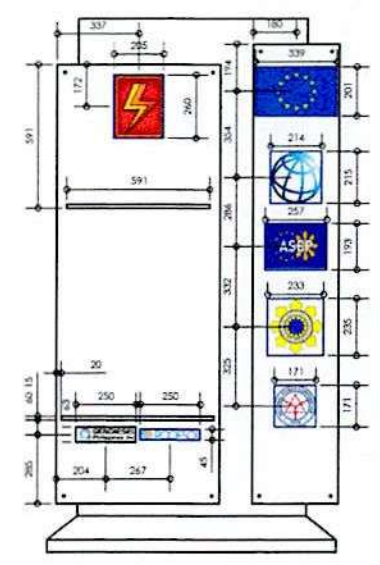
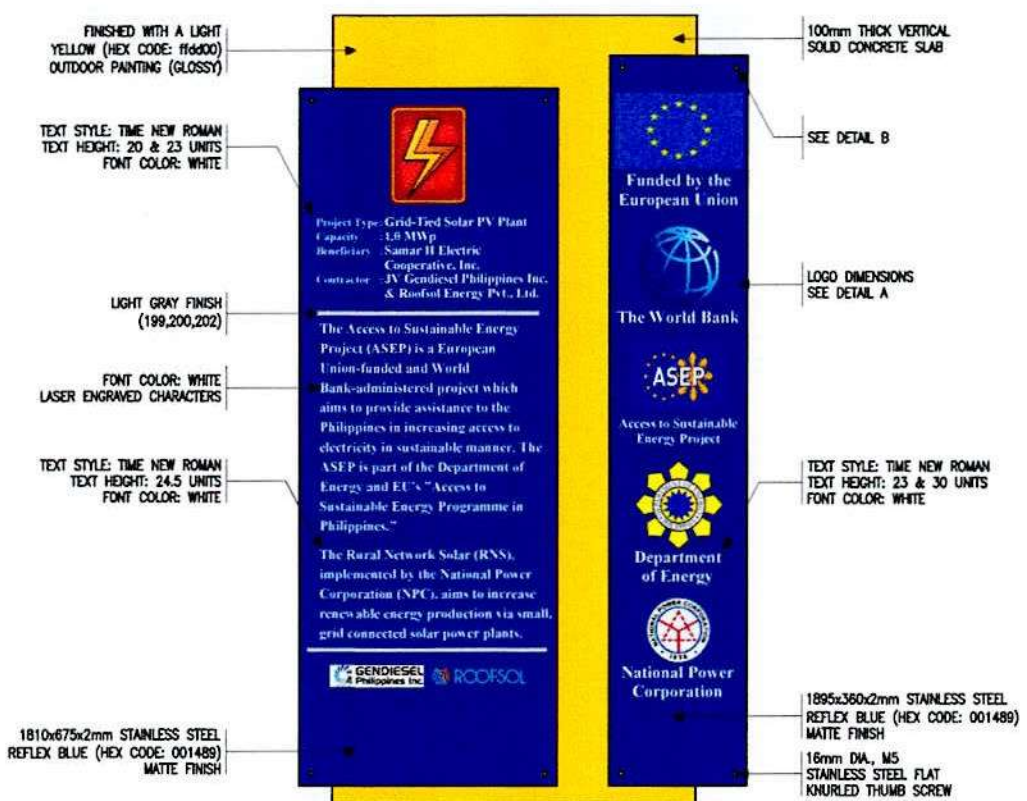

SITE MARKER FOUNDATION DETAILS  
SCALE: NTS

OWNER:		<b>NATIONAL POWER CORPORATION</b> AGHAM ROAD, DILIMAN, QUEZON CITY	
PROJECT: DESIGN, SUPPLY AND INSTALLATION OF 7x1.0MWp GRID-TIED SOLAR FARM FOR LUZON, VISAYAS AND MINDANAO ELECTRIC COOPERATIVES (LOT 5 - SAMELCO II)			
LOCATION: POBLACION 6, PARANAS, WESTERN SAMAR			
TITLE:		<b>SITE MARKER</b>	
DESIGNED	BY	CHKD	DATE
DRAWN			
REVIEWED	PRINCIPAL ENGR. / ARCHT.		SUBMITTED
CIVIL/ARCHT			RECOMMENDED
ELEC.			APPROVED
MECH.			
DWG. NO.		SPECS. NO.	
SCALE: AS SHOWN		<b>SAMPLE DRAWING</b>	
REV.		DATE	
NATURE OF REVISION		BY	
		CHKD.	
		RECD.	
		APPD.	
		REV. <b>0</b>	

REV.	DATE	NATURE OF REVISION	BY	CHKD.	RECD.	APPD.

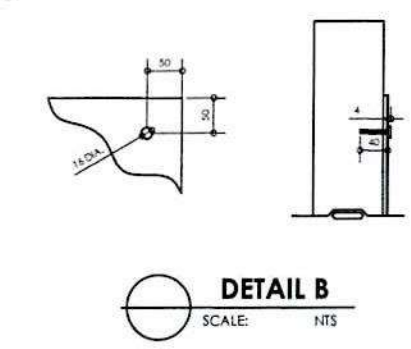
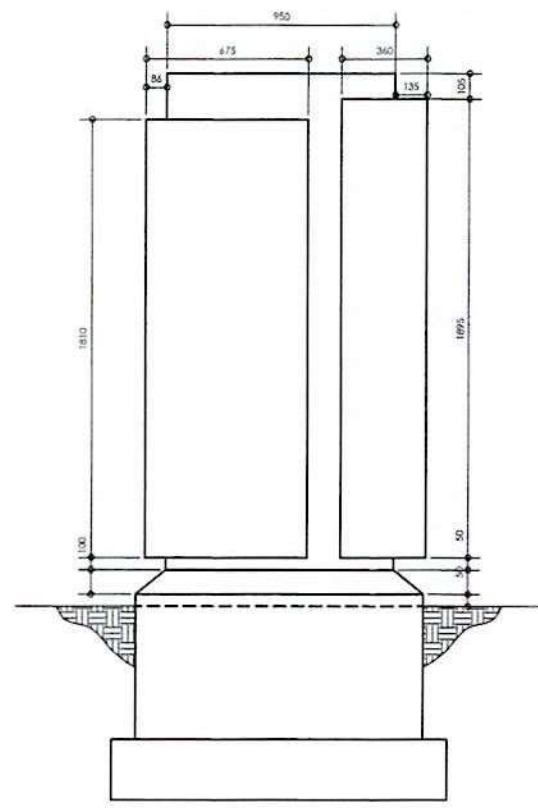
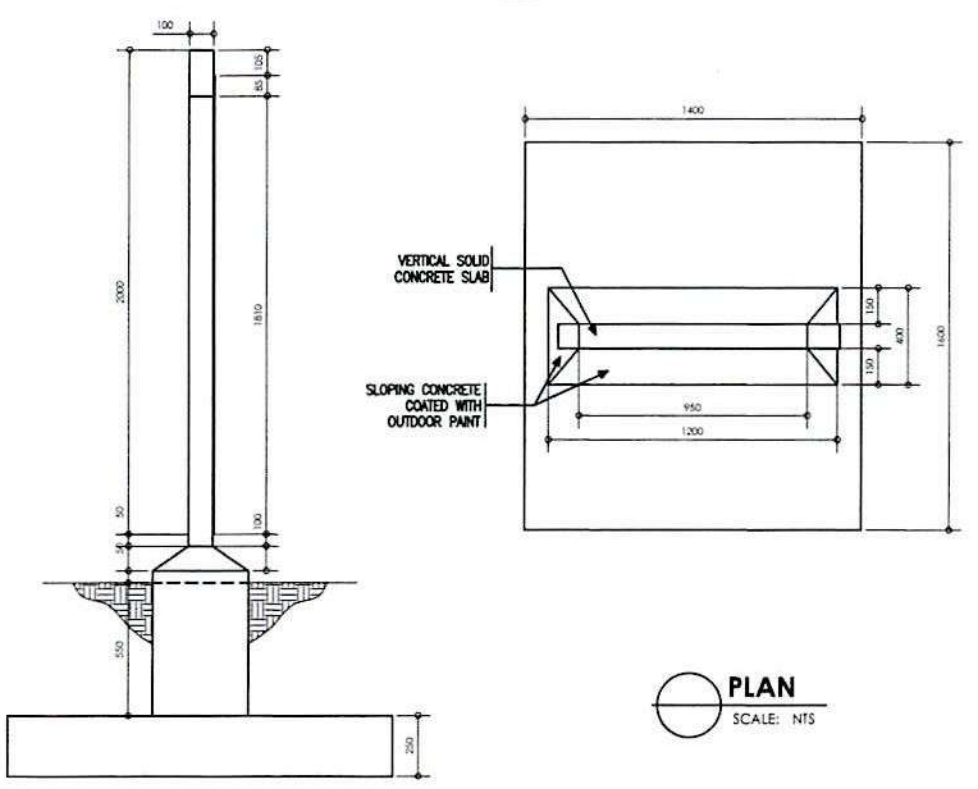
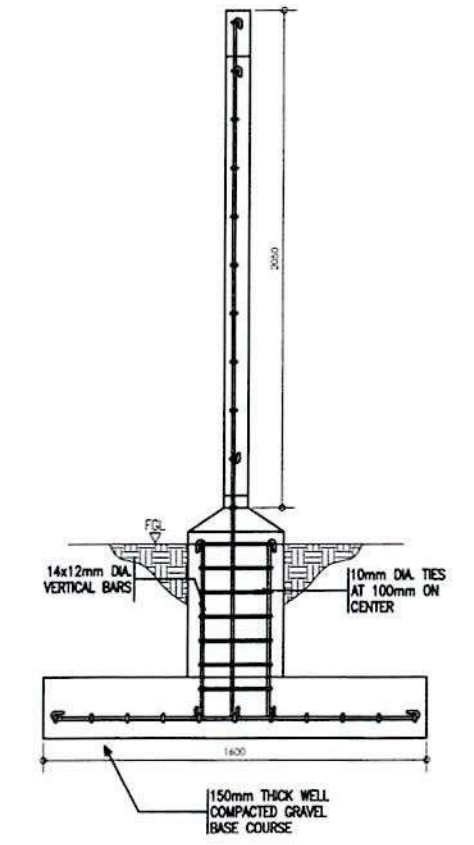
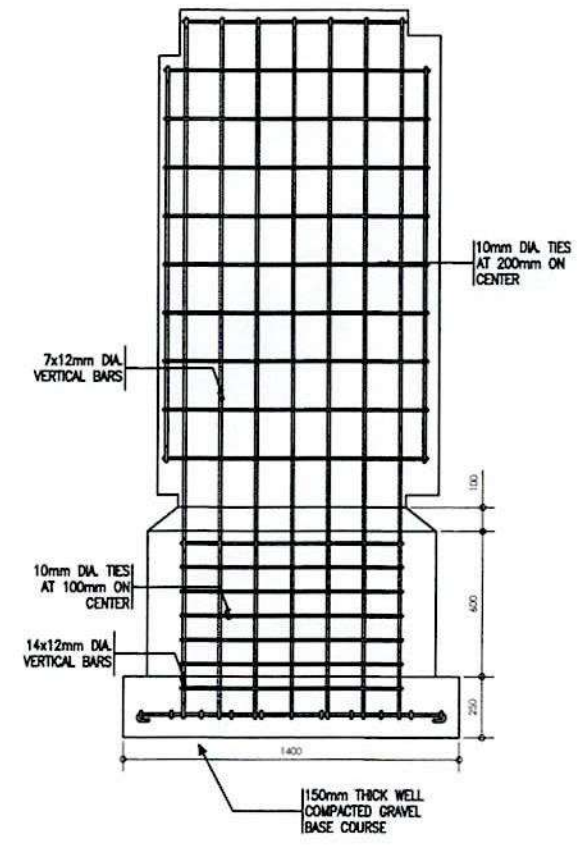
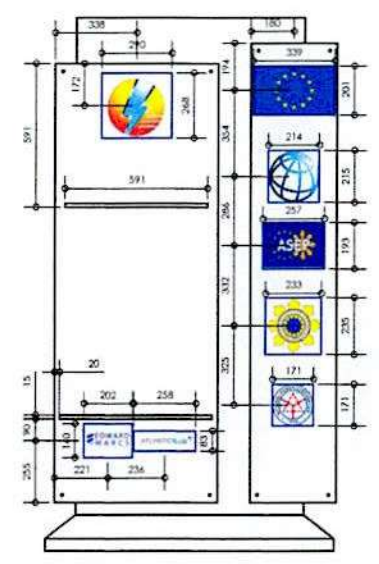
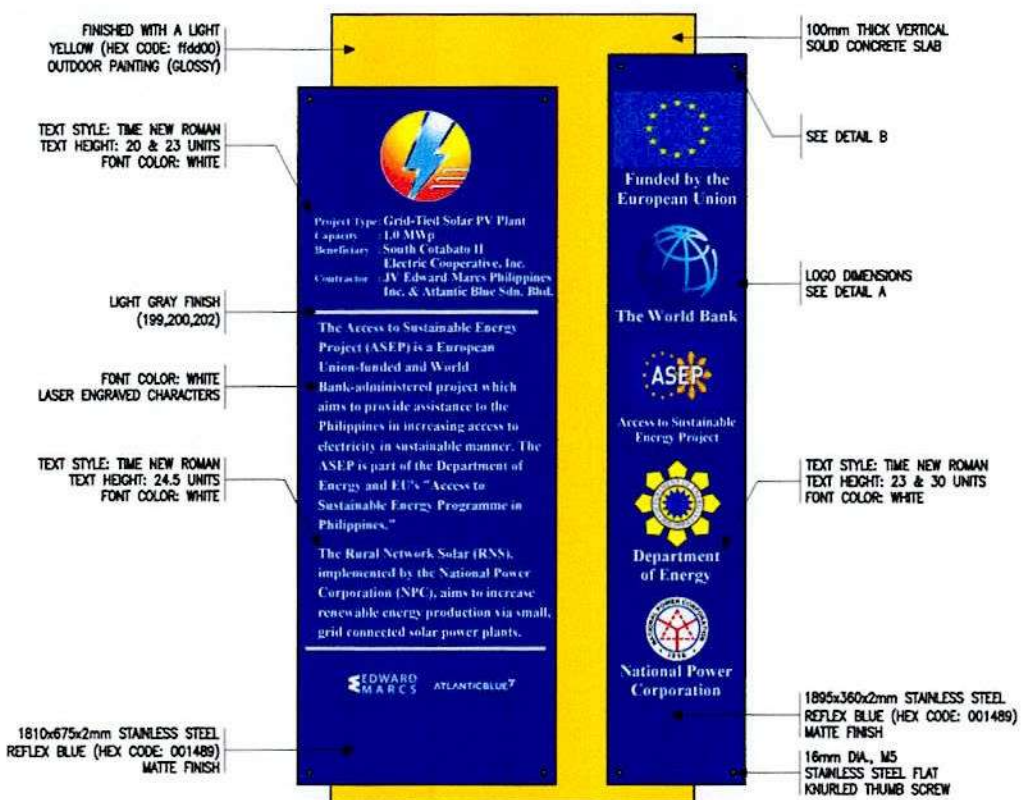

SITE MARKER FOUNDATION DETAILS  
SCALE: NTS

OWNER:		<b>NATIONAL POWER CORPORATION</b> AGHAM ROAD, DILIMAN, QUEZON CITY	
PROJECT: DESIGN, SUPPLY AND INSTALLATION OF 7x1.0MWp GRID-TIED SOLAR FARM FOR LUZON, VISAYAS AND MINDANAO ELECTRIC COOPERATIVES (LOT 6 - SOCOTECO II)			
LOCATION: BRGY. APOPONG, GENERAL SANTOS CITY, SOUTH COTABATO			
TITLE:		<b>SITE MARKER</b>	
DESIGNED	BY	CHKD	DATE
DRAWN			SUBMITTED: _____
REVIEWED	PRINCIPAL ENGR. / ARCHT.		RECOMMENDED: _____
CIVIL/ARCHT			APPROVED: _____
ELEC.			
MECH.			
DWG. NO.		SPECS. NO.	
SCALE: AS SHOWN		<b>SAMPLE DRAWING</b>	
REV.		REV. <b>0</b>	

REV.	DATE	NATURE OF REVISION	BY	CHKD.	RECD.	APPD.

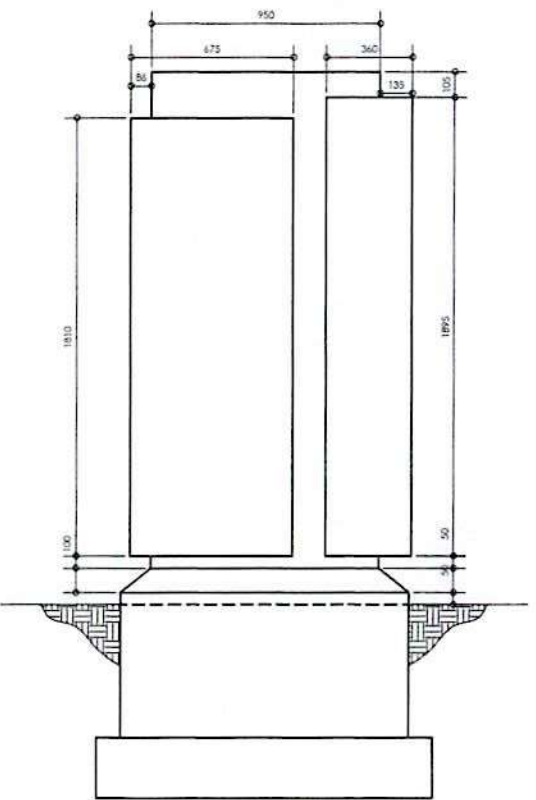
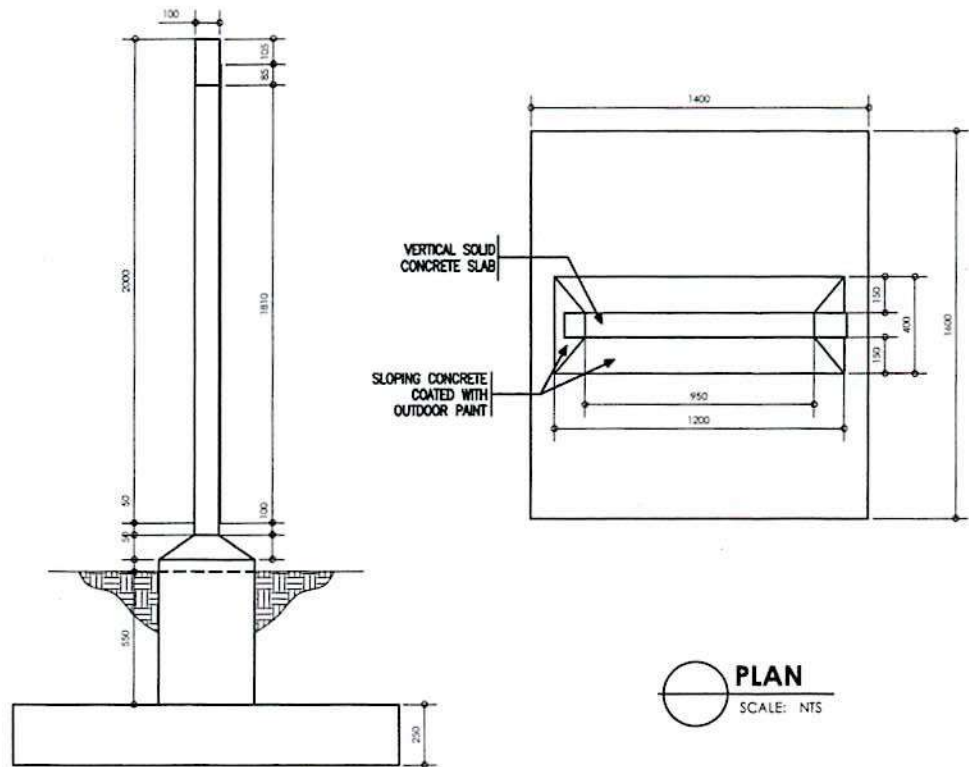
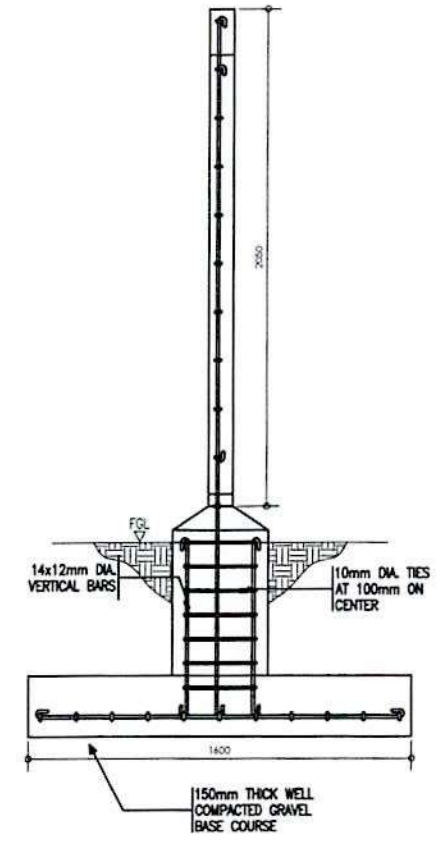
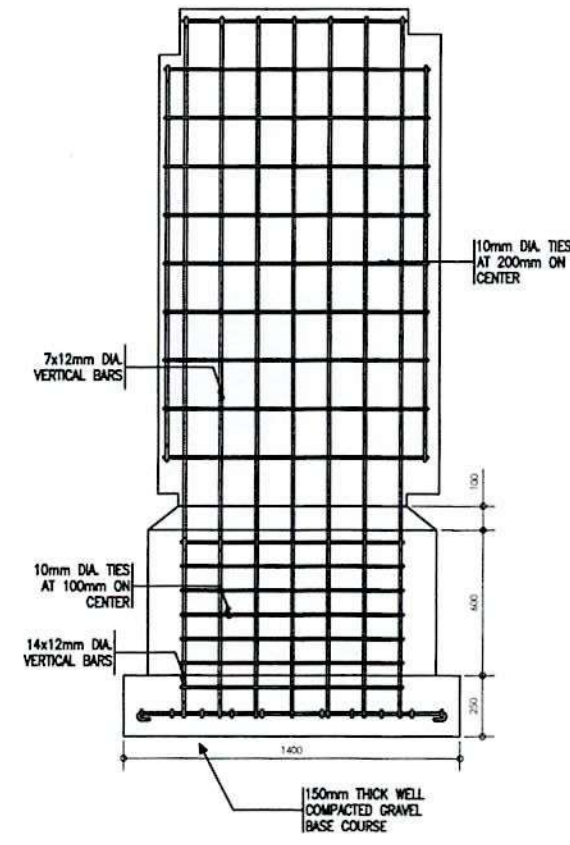
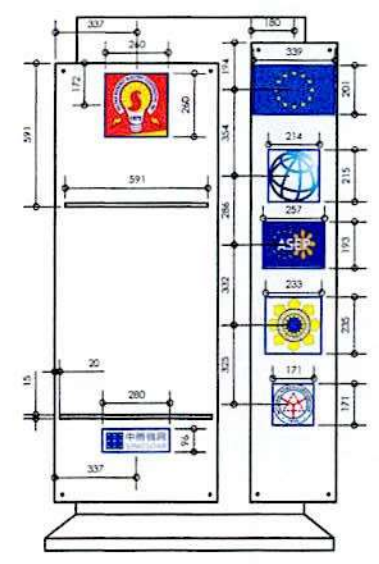
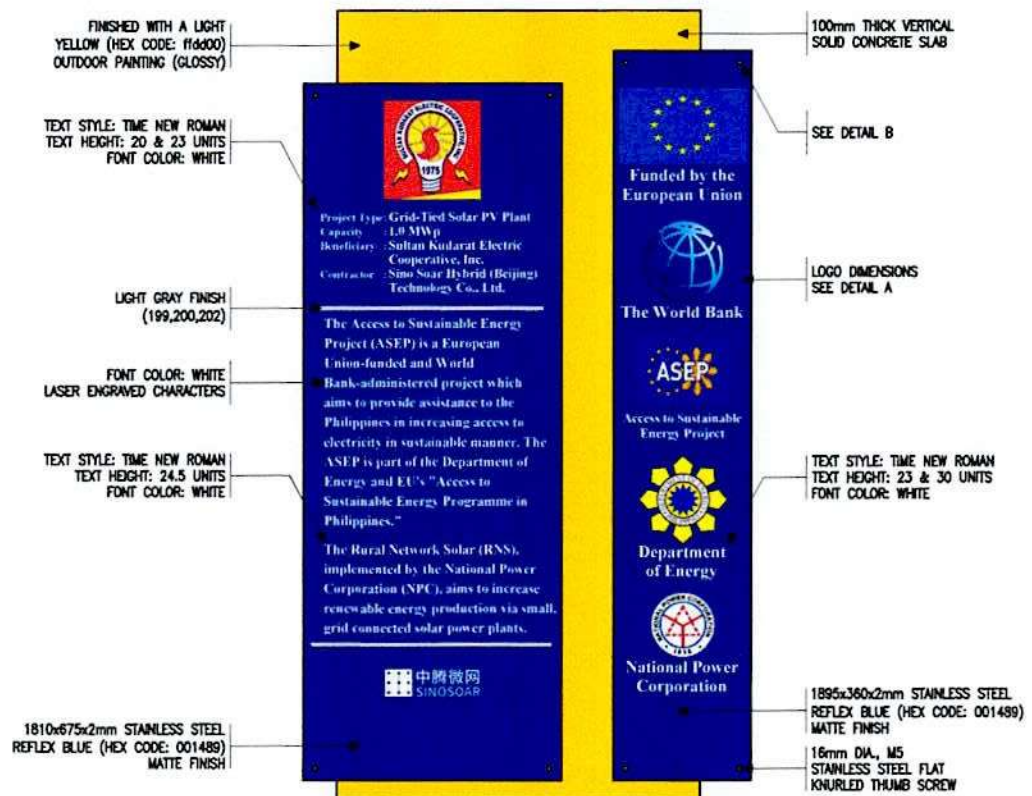

SITE MARKER FOUNDATION DETAILS  
SCALE: NTS

OWNER:		 <b>NATIONAL POWER CORPORATION</b> AGHAM ROAD, DILIMAN, QUEZON CITY	
PROJECT: DESIGN, SUPPLY AND INSTALLATION OF 7x1.0MWp GRID-TIED SOLAR FARM FOR LUZON, VISAYAS AND MINDANAO ELECTRIC COOPERATIVES (LOT 7 - SUKELCO)			
LOCATION: KALANDAGAN, TACURONG CITY, SULTAN KUDARAT			
TITLE:		<b>SITE MARKER</b>	
DESIGNED	BY	CHKD	DATE
DRAWN			
REVIEWED	PRINCIPAL ENGR. / ARCHT.		SUBMITTED
CIVIL/ARCHT			RECOMMENDED
ELEC.			APPROVED
MECH.			
DWG. NO.		SPECS. NO.	
SCALE: AS SHOWN		<b>SAMPLE DRAWING</b>	
		REV. <b>0</b>	

REV.	DATE	NATURE OF REVISION	BY	CHKD.	RECD.	APPD.